

Specifications

MODEL **GTH-4514**

MEASUREMENTS	Metric	Imperial
Lifting height (max)	13.7 m	44 ft 9 in
Lifting capacity (max)	4,500 kg	9,920 lbs
Lift capacity at maximum height	3,500 kg	7,716 lbs
Lift capacity at maximum reach	1,250 kg	2,755 lbs
Forward reach (max)	9.3 m	30 ft 5 in
Reach at maximum height	0.85 m	2 ft 7 in
A Height	2.56 m	8 ft 4 in
B Height at steering wheel	1.92 m	6 ft 3 in
C Width	2.33 m	7 ft 6 in
D Inside cab width	0.91 m	3 ft
E Track	1.92 m	6 ft 3 in
F Wheelbase	2.85 m	9 ft 3 in
G Length at front wheels	4.52 m	14 ft 8 in
H Length at fork-holder plate	5.99 m	19 ft 6 in
I Ground clearance	0.46 m	1 ft 5 in
J Overall width, stabilisers extended	2.93 m	9 ft 6 in
K1 Obstruction angle	39°	39°
K2 Departure angle	45°	45°

PRODUCTIVITY

Lifting/lowering speed	17 sec./16 sec.	17 sec./16 sec.
Extension/retraction speed	25 sec./19 sec.	25 sec./19 sec.
Inside/outside turning radius	1.30 m/3.99 m	4 ft 2 in/13 ft 1 in
Break out force	7,400 kg	16,314 lbs
(with 800L shovel SAE J 732/80)		
Towing capacity at dynamometer	8,300 kg	18,298 lbs
Travel speed	35 km/h	22 mph
Gradeability (Unloaded)	40%	40%
(Full Load)	25%	25%
Fork-holder plate rotation	145°	145°
Floating forks	L 1200 mm	L 3 ft 9 in
	Section 120x50 mm	Section 5 in x 2 in
Tyres (DIN 70361)		405/70-20" 8 hole rim

POWER

Engine	Perkins turbo Diesel, direct injection, low emissions. Water cooled, 4 cylinders Power 74.4 kw (101 Hp)	
Tank capacities		
Fuel	135 L	29.7 gal
Engine oil	11.5 L	2.5 gal
Coolant	15 L	3.3 gal
Hydraulic oil	150 L	33 gal

WEIGHT

Weight*	11,400 kg	25,132 lbs
---------	-----------	------------

STANDARDS COMPLIANCE

Operating cab conforms to EEC directives 86/295 (ROPS) and 86/296 (FOPS)

* Weight will vary depending on options and/or country standards **EN1459**
AS1418-19

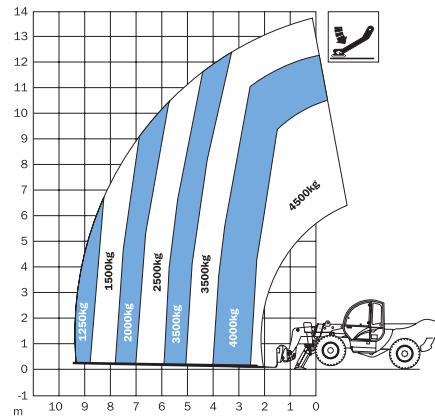
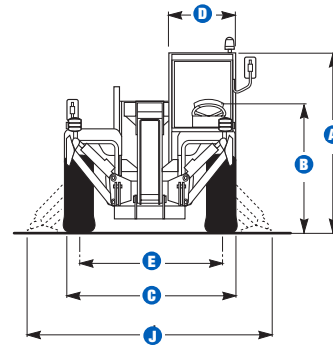
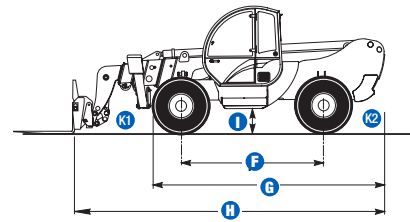

Lift capacity chart (with stabilisers)

Features

STANDARD FEATURES

MEASUREMENTS

- 4,500 kg (9,920 lbs) maximum lift capacity
- 13.7 m (44 ft 9 in) maximum lift height
- 9.3 m (30 ft 5 in) maximum forward reach

PRODUCTIVITY

- Four-wheel drive
- 3 steering modes:
 - front wheel steer
 - crab steer
 - coordinated steer
- Oscillating rear axle with axle lock out
- Front hydraulic outriggers
- Chassis levelling on front axle (+or-8°)
- Limited slip differential
- Closed loop hydrostatic drive for smooth and precise positioning
- Multi function – electroproportional joystick
- Brakes: multi-disc, oil immersed, self adjusting
- Power assisted steering
- Easy access to components for maintenance
- Floating forks
- Attachment holder plate with mechanical coupling
- Adjustable steering wheel
- Fully adjustable seat
- Lockable fuel tank
- Quick coupling of tools from cab
- Windshield protection grid
- Longitudinal stability control system with: visual display with coloured LEDs, audible alarm, automatic lockout of boom extension and lowering.
- Lockout of stabilisers and chassis levelling with boom raised.

POWER

- Perkins turbo Diesel, direct injection, low emissions. Water cooled, 4 cylinders
Power 74.4 kw (101 Hp)



OPTIONS & ACCESSORIES

PRODUCTIVITY

- Air conditioning
- Spare wheel
- Adjustable spotlights
- Tyres and rims (405/70-24)
- Load management system

ATTACHMENT OPTIONS

A large range of attachments are currently available. Please contact Genie or your nearest Genie telehandler dealer.

Genie Australia

591 Boundary Road, Darra, Qld 4076
PO Box 394, Richlands, Qld 4077
Tel: + 61 7 3375 1660
Toll Free In Australia: 1800 331 660
Fax: + 61 7 3375 1002

European Offices

UK

The Maltings
Wharf Road
Grantham NG31 6BH
UK
Tel: +44 (0)1476 584333
Fax: +44 (0)1476 584334

France

10, ZA de la Croix St. Mathieu
28320 Gallardon
France
Tel: +33 (0)2 37 26 09 99
Fax: +33 (0)2 37 26 09 98

Germany

Finienweg 3
28832 Achim/Bremen
Germany
Tel: +49 (0)4202 8852-0
Fax: +49 (0)4202 8852-25

Spain

Gai`a 31, Pol. Ind. Pl`a d'en Coll
08110 Montcada i Reixac
Barcelona
Spain
Tel: +34 93 572 50 90
Fax: +34 93 572 50 91

Scandinavia

Tagenevägen 72
425 37 Hisings Kärra
Sweden
Tel: +46 31 57 51 00
Fax: +46 31 57 90 20

Genie United States

18340 NE 76th Street
P.O. Box 97030
Redmond, Washington 98073-9730
USA
Tel: +1 425 881-1800
Fax: +1 425 883-3475

WEB: www.genieindustries.com.au

Distributed By:

For further information, please contact your local distributor or the Genie Industries sales office listed. Product specifications are subject to change without notice or obligation. The photographs and drawings in this brochure are for illustrative purposes only. Refer to the appropriate Operator's Manual for instructions on the proper use of this equipment. Failure to follow the appropriate Operator's Manual when using our equipment or to otherwise act irresponsibly may result in serious injury or death. Prices and specifications subject to change without notice. The only warranty applicable is the standard written warranty applicable to the particular product and sale. Genie makes no other warranty, expressed or implied. Products and services listed may be trademarks, service marks or trade-names of TEREX Corporation and/or its subsidiaries in the USA and other countries and all rights are reserved. Copyright © 2006 Genie Industries, Inc. "Genie" is a Registered Trademark of Genie Industries, Inc. in the USA and many other countries. Genie is a TEREX Company.

06/06. Part No. B108016AUS

www.genieindustries.com.au