

TOUCAN 10E-L

MAST BOOM LIFT



Performance

Working height	10.10 m
Platform height	8.10 m
Working outreach	3.38 m
Up and over height	6.51 m
Swing (not continuous)	345°
Platform capacity ¹	200kg (2 persons indoor and 1 person outdoor)
Jib - overall length	1.60 m
Jib - range of articulation	126° (+65°/ -61°)
Platform size standard platform (LxW)	0.70 x 0.90 m
Drive speed - lowered	5.5 km/h
Drive speed - elevated	0.75 km/h
Drive speed - full elevation	0.40 km/h
Turning radius (outside)	1.99 m
Turning radius (inside)	0.55 m
Gradeability	25%
Machine weight ²	2,600 kg

1. Capacity shown is maximum two persons indoor and one person outdoor (12.5 m/s wind speed)

2. Certain options or country standards may increase weight and/or dimensions.

Standard Specifications

Power

Electrical system	24V DC
Batteries (AGM)	24V - 260 A/hr
Charger	24V - 27A
Drive motors	Dual AC motors
Brakes	Disc

Hydraulic System

- Electrical (pump) motor 3kW 24V DC
- Hydraulic system 7.5 L

Tyres

- Tyres (non-marking solid) 406 x 125 mm

Standard Features

- 0.90 m x 0.70 m (L x W) steel platform
- Slide bar rear entry
- Full proportional drive and slew joystick control with integral thumb steer switch
- Mini joysticks provide proportional mast and jib lift/lower functions
- 1.60 m articulating jib
- Load sensing system
- Large tool tray
- Two wheel direct electric drive
- Brushless AC drive motors
- Auto power save when idle
- Low charge function cut-out
- On-board diagnostics with integral display
- Automatic rear wheel brakes
- Sculptured polyester hoods
- Heavy duty steel roller mast with 345° rotation
- Chain slack detection system
- 2.5 degree tilt alarm and indicator light
- Passive pothole protection system
- 0.99 m wide frame
- Lifting /tie down rings
- Ground control selector switch with key lock
- Battery discharge indicator
- Hour meter
- Horn
- Drive orientation system
- Lanyard anchor points
- Zenon strobe light
- Acoustic motion alarm
- Manual descent system



Accessories & Options

- 8 mm air line to platform
- Food Compatible Hydraulic Oil
- Low Temperature Hydraulic Oil
- AC Outlets to platform incl. ELCB
- Platform work lights 70W
- Synthetic Biodegradable Hydraulic Oil

TOUCAN 10E-L

MAST BOOM LIFT



Dimensions

All dimensions are approximate.

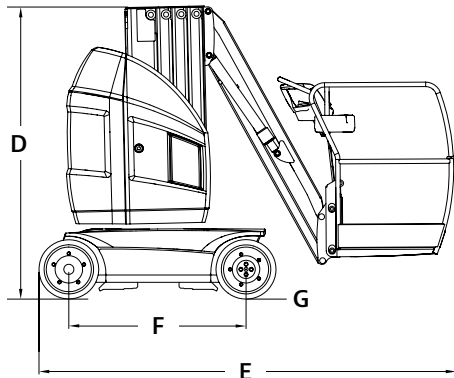

A. Platform size standard platform (L x W)	0.70 x 0.90 m
B. Overall width	0.99 m
C. Tailswing	12 cm
D. Stowed height	1.99 m
E. Overall length (standard platform)	2.82 m
F. Wheelbase	1.20 m
G. Ground clearance	10 cm

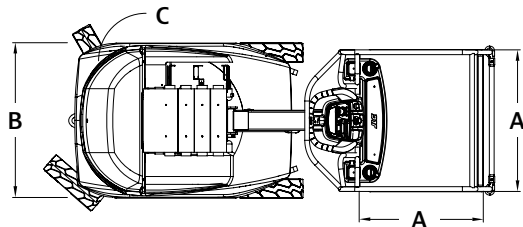

Reach Diagram

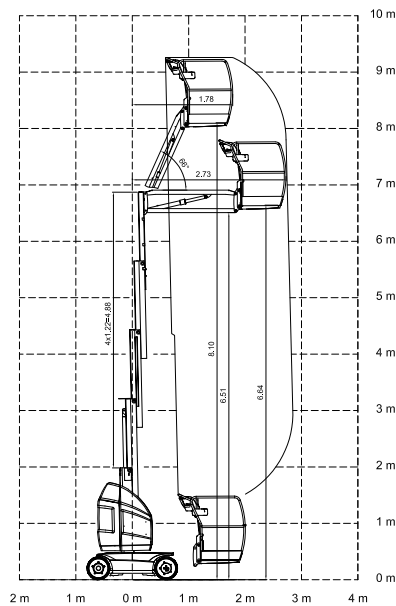

The JLG "1 & 5" Warranty

JLG Industries, Inc. backs its products with its exclusive "1 & 5" Warranty. We provide coverage on all products for one (1) full year and cover all specified major structural components for five (5) years. Due to continuous product improvements, we reserve the right to make specification and/or equipment changes without prior notification. This machine meets or exceeds AS/NZS 1418.10 2011 as originally manufactured for intended applications.

JLG Industries (Australia)

358 Park Road
Regents Park, NSW 2143
Telephone 02 8718 6300
Fax 02 8718 6377
www.jlg.com.au

An Oshkosh Corporation Company