

## X17J PLUS

COMPACT CRAWLER BOOM



### Performance

Working Height	16.96 m
Platform Height	14.96 m
Working Outreach	7.65 m
Up and Over Height	7.80 m
Swing	360° (Non-continuous)
Jib - Overall Length	1.68 m
Jib - Range of Articulation (+/-)	89° (+0/-89°)
Platform Capacity (unrestricted)	230 kg
Platform Size	0.69 m x 1.34 m
Stowed Width	1.48 m
Machine Weight*	2,230 kg
Gradeability	28%
Maximum Operating Slope	16°
Maximum Approach/Depart Angles	20°
Width of Undercarriage (Retracted/Extended)	0.79 m/1.09 m

\*Certain options will increase weight.

### Standard Specifications

#### Power Source

Petrol	Petrol Engine Honda iGX390 11.7 kW AC Electric Motor 230V, 50 Hz, 2.2 kW
Diesel	Diesel Engine Hatz 1B40 7.5 kW, 10 hp AC Electric Motor 230V, 50 Hz, 2.2 kW
Battery	100 AH, 48V Electric engine with lithium battery package, including battery charger

#### Tyres

- Low Profile Non-marking Rubber Tracks 1.24 m x 0.18 m x 0.30 m

### Standard Features

- SkyGuard® Enhanced Control Panel Protection
- 0.69 m x 1.34 m Aluminium Two-person Platform
- Slide Bar Rear Entry
- Footswitch
- Full Proportional Control
- Articulating Jib
- Powered Platform Rotator (124°)
- Remote Control (Via Cable to Platform)
- Full Remote Control of Drive and Stabilization
- Multi-lingual LCD Display on Platform Console
- Platform Console Position Sensor and Lock
- Envelope Management Load Sensing System
- Platform Designed for Ease of Removal/Changeover
- 6.5 mm Air Line to Platform
- Engine Protection
- Rubber Outrigger Pads
- Cylinder Rod Protection on Outriggers
- Automatic Cut-out When Out of Level
- Powered Track Extension/Retraction
- 360° Non-continuous Turntable Rotation
- Turntable Alignment Sensor and Gauge
- Three Emergency Descent Systems
- Electro-hydraulic Controls
- Full Pressure Hydraulic Controls
- 2nd Drive Speed (High)
- Lifting/Tie Down Points
- Forklift Pockets

### Accessories & Options

- AC Outlet to Platform, Including ELCB
- Fire Extinguisher



## X17J PLUS

COMPACT CRAWLER BOOM



### Dimensions

All dimensions are approximate.

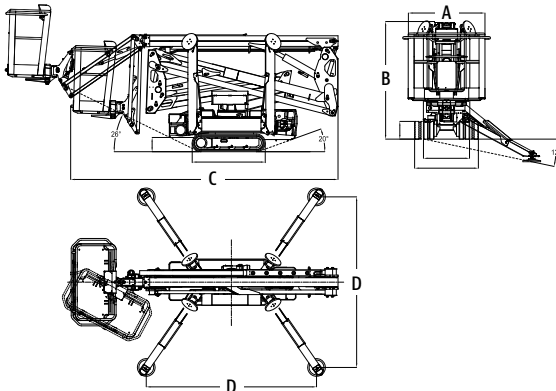

A. Stowed width (without platform):	0.80 m
B. Stowed height (on tracks):	2.00 m
C. Stowed length (on tracks):	4.53 m
D. Outrigger footprint:	2.89 m x 2.88 m

### Reach Diagram

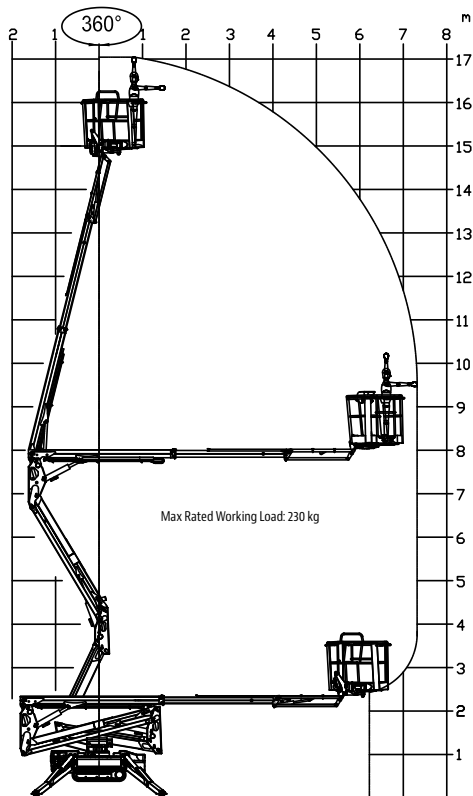

### The JLG "1 & 5" Warranty

JLG Industries, Inc. backs its products with its exclusive "1 & 5" Warranty. We provide coverage on all products for one (1) full year and cover all specified major structural components for five (5) years. Due to continuous product improvements, we reserve the right to make specification and/or equipment changes without prior notification. This machine meets or exceeds AS/NZS 1418.10 2011 as originally manufactured for intended applications.

**JLG Industries (Australia)**  
 358 Park Road  
 Regents Park, NSW 2143  
 Telephone 02 8718 6300  
 Fax 02 8718 6377  
[www.jlg.com.au](http://www.jlg.com.au)

**An Oshkosh Corporation Company**