

PANORAMIC P 60.10

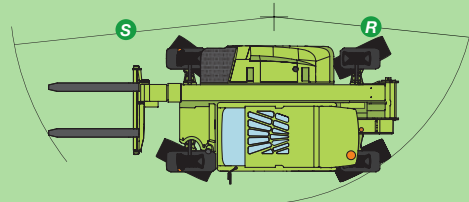

KEY SPECIFICATIONS

Total weight unladen with forks (kg)	9800
Maximum load capacity (kg)	6000
Maximum lift height (m)	9.30
Maximum forward reach (m)	5.3
Lift height at maximum capacity (m)	5.8
Forward reach at maximum load capacity (m)	1.6
Load capacity at maximum height (kg)	1200
Load capacity at maximum forward reach (kg)	1200
Engine (make/number of cylinders)	Perkins/4
Tier 3 engine power (kW/hp)	74.5/100
Fuel capacity (l)	150
Maximum speed (kph)	40
Load -sensing hydraulic pump (bar-l/min)	210-108
Hydraulic oil capacity (l)	110
Electrical circuit (V)	12
Battery (Ah)	100
Cab compliant with ROPS/FOPS standards	✓
4x1 Electro Proportional joystick controls	✓
Tac-Lock hydraulic attachment coupling	✓
Auxiliary boom hydraulics	✓
Two standard forks (1200mm)	✓
Hydrostatic transmission	✓
Finger touch direction control	✓
Inching pedal for precise control	✓
Permanent 4 wheel drive	✓
Four wheel steering	✓
Dry type disc brakes on all wheels	✓
Automatically locking parking brake	✓
445/65R22.5 tyres	✓
Rear differential lock	✓
Four cab working lights (2f & 2r)	✓
12V electrical on boom head	✓
Air suspension seat	✓
Front window protection	✓
Full size cab with air conditioning	✓
Stability control system	✓

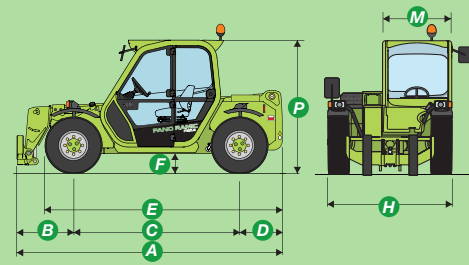

DIMENSIONS

A (mm)	5345
B (mm)	1235
C (mm)	2875
D (mm)	1300
E (mm)	4645
F (mm)	480
H (mm)	2330
M (mm)	995
P (mm)	2440
R (mm)	3950
S (mm)	4970

P60.10 Load Chart - Standard forks

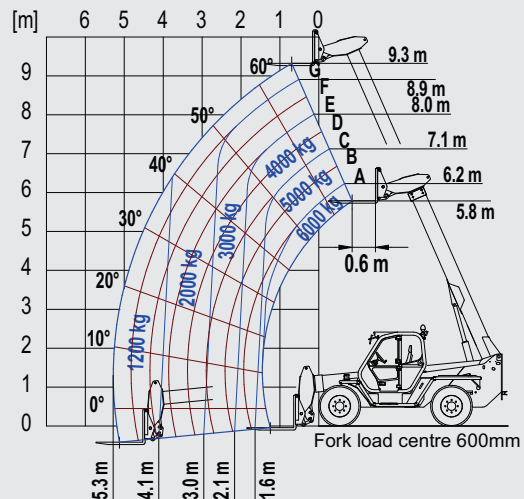

The Merlo Panoramic P60.10 is designed for exactly what is needed on site, a tough reliable tool, easy to use and versatile. The Merlo design gives the advantage of bigger performance in a smaller lighter machine with added flexibility. For added productivity, a large range of optional attachments including buckets, crane hooks, winches, jibs and man platforms add to the versatility of the P60.10. The standard hydraulic quick attach fork carriage allows attachments to be quickly changed using controls in the cab. The smooth boom hydraulics provides greater control and accurate placement. The Merlo P60.10 can move 6000 kg, lift up to 9.3m height and travel up to 40 km/h, with the extra benefits of a full size comfort cab. The 3 mode steering adds to the ease of operation. You benefit from easy to use versatile equipment, an increase in efficiency and productivity, and the safest telehandler with 50 years of specialist experience.

Merlo reserves the right to modify and update the contents of this document at any time. Information and technical data are as available at time of printing. For current information on Merlo products please contact your Merlo dealer.



1300 657325
merloaustralia.com.au

ABN 87116110751

P60.10.ver2.19.6