



Aerial Work Platforms

Genie® Runabout™ Contractor

Specifications

MODEL	GRC™ -12	
Measurements	Metric	US
Working height*	5.66 m	18 ft
Platform height	3.66 m	12 ft
A A Platform dimensions (length x width)		
Ext Platform dimensions - retracted	99 x 75 cm	39 x 29.5 in
Ext Platform dimensions - extended	1.4 m x 75 cm	55 x 29.5 in
A Height - stowed	1.70 m	67 in
A Length - stowed	1.37 m	4 ft 6 in
A Width	80 cm	2 ft 7.5 in
A Ground clearance - center	6.3 cm	2.5 in

Productivity

Max platform occupancy (indoor/outdoor) ¹	2/-	2/-
Lift capacity	227 kg	500 lbs
Drive speed - stowed	4.0 km/h	2.5 mph
Drive speed - raised	0.8 km/h	0.5 mph
Gradeability**	30%	30%
Turning radius - inside	zero	zero
Turning radius - outside	1.35 m	4 ft 5 in
Raise / lower speed	12 / 16 sec	12 / 16 sec
Controls	24V DC proportional	24V DC proportional
Tyres - solid non-marking	25 x 8 x 20 cm	10 x 3 x 8 in

Power

Power source	24V (four 6V 225 Ah batteries)	
Hydraulic system capacity	8.33 L	2.2 gal

Sound & Vibration Levels

Sound pressure level (ground workstation)	<70 dBA	
Sound pressure level (platform workstation)	<70 dBA	
Vibration	<2.5 m/s ²	<98.4 in/s ²

Weight***

	950 kg	2,094 lbs
--	--------	-----------

Standards Compliance

ANSI A92.6, CSA B354.2, CE Compliance, AS 1418.10

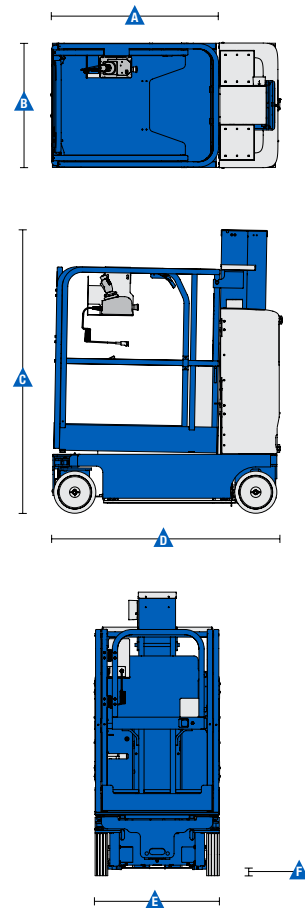

¹ Indoor use only.

* The metric equivalent of working height adds 2 m to platform height. U.S. adds 6 ft to platform height.

** Gradeability applies to driving on slopes. See operator's manual for details regarding slope rating.

*** Weight will vary depending on options and/or country standards.



Aerial Work Platforms

Genie® Runabout™ Contractor

Features

Standard Features

Measurements

- 5.66 m (18 ft) working height
- 3.66 m (12 ft) platform height
- Up to 227 kg (500 lbs) lift capacity

Productivity

- 2-person rated
- Smart Link™ control system (joystick, 2 proportional lift speeds & 2 selectable proportional drive speeds, user-friendly diagnostics)
- Auxiliary platform lowering
- Low 39 cm (15.5 in) platform entry height
- Work station tray
- Steel tube-in-tube mast system
- Compact base 80 cm x 1.37 m (31.5 x 54 in)
- Ground clearance 6.4 cm (2.5 in) (stowed)
- Fully proportional lift and drive controls
- Battery charge indicator
- On-board diagnostic system
- Descent and tilt alarm
- Zero inside turning radius
- Dual wheel brakes
- Hydraulic brake release
- Pothole protection
- Hinged rear ABS covers for easy access to all major electrical and hydraulic components
- Tie down attachment points
- Overhead crane attachment point
- Large forklift pockets access
- Certified load sensor
- Dual flashing beacons
- Motion alarm
- Automotive-style horn
- Drive cutout while charging

Standard Features

Platform

- 99 cm x 75 cm (39 x 29.5 in) steel platform and extension deck with swing gate

Power

- 24V (four 6V 225 Ah batteries) with automatic 25 amp battery charger

Tyres

- Non-marking solid

Options & Accessories

Productivity Options

- 240 V power to platform
- Biodegradable hydraulic oil

Power Options

- AGM maintenance-free batteries



Genie – Toll free number 1800 788 633

Brisbane

HEAD OFFICE
33 Kimberley Street
Darra QLD 4076

Sydney

74 Glendenning Road
Glendenning NSW 2761

Melbourne

374 Hammond Road
Dandenong VIC 3175

Adelaide

16-18 Nixon Road
Wingfield SA 5013

Perth

126 Sheffield Road
Welshpool WA 6106

Darwin

33 McCourt Road
Yarrawonga NT 0830

Genie USA

18340 NE 76th Street
P.O. Box 97030
Redmond, Washington
98073-9730

Distributed By:

Effective Date: July, 2015. Product specifications and prices are subject to change without notice or obligation. The photographs and/or drawings in this document are for illustrative purposes only. Refer to the appropriate Operator's Manual for instructions on the proper use of this equipment. Failure to follow the appropriate Operator's Manual when using our equipment or to otherwise act irresponsibly may result in serious injury or death. The only warranty applicable to our equipment is the standard written warranty applicable to the particular product and sale and we make no other warranty, express or implied. Products and services listed may be trademarks, service marks or trade names of Terex Corporation and/or their subsidiaries in the USA and many other countries. Genie is a registered trademark of Terex South Dakota, Inc. © 2015 Terex Corporation.

GRC12 150729

www.genielift.com.au