

ES SERIES - LIGHTWEIGHT

ES1330L/ES1530L ELECTRIC SCISSOR LIFTS - INDOOR AND OUTDOOR RATED



Performance

Platform Height-Elevated (Indoor/Outdoor)		
ES1330L	13 ft / 13 ft	3.8 m / 3.8 m
ES1530L	15 ft / 10 ft	4.5 m / 3 m
Platform Capacity (Indoor/Outdoor)		
ES1330L	500 lb / 500 lb	227 kg / 227 kg
ES1530L	500 lb / 500 lb	227 kg / 227 kg
Capacity on Platform Extension		
	250 lb	115 kg
Number of Occupants (Indoor/Outdoor)		
ES1330L	2 / 1	
ES1530L	1 / 1	
Lift/Lower Time		
	25/15 seconds	
Maximum Drive Height		
	Fully Elevated	
Weight*		
ES1330L	1,984 lb	900 kg
ES1530L	1,940 lb	880 kg
Ground Bearing Pressure		
ES1330L	119 psi	8.3 kg/cm ²
ES1530L	116 psi	8.1 kg/cm ²
Drive Speed-Elevated		
	0.5 mph	0.8 km/h
Drive Speed-Lowered		
	2.4 mph	3.8 km/h
Gradeability		
	25%	
Tilt Rating		
Fore and Aft		
	3.0 degrees	
Side to Side		
ES1330L - Indoor/Outdoor	1.75 degrees / 1.5 degrees	
ES1530L - Indoor/Outdoor	2.5 degrees / 1.5 degrees	
Turning Radius (Inside)		
	Zero	
Turning Radius (Outside)		
	55 in	14 m

* Certain options or country standards will increase weight.



**NOW
OUTDOOR
RATED**

Standard Specifications

Power Source

Batteries	2 x 12V 105 amp-hr
Charger	27 Amp
Drive	24V Electric DC

Hydraulic Reservoir

• Capacity	13 gal	5 L
• Pump	Fixed Displacement Gear	

Tires

• Tire Size/Type (Non-Marking)	10 x 3 in	255 x 75 mm
--------------------------------	-----------	-------------

Brakes

- Electric/Friction

Standard Features

- Proportional Controls
- Battery Condition Indicator
- All Motion Alarm
- DeltaQ - 27 amp Multi-Function Universal Charger
- Horn
- Hourmeter
- Tilt Alarm and Light
- AC Receptacle in Platform
- Active Pothole Protection System
- Lifting and Tie Down Points
- Fork Lift Pockets
- Lanyard Attach Points
- Steel Swing-Out Doors
- Visual Variable Tilt Indicator
- Manual Descent Cable
- Diamond Tread Steel Deck
- Greaseless Kingpin Joints
- Analyzer Port for Diagnostics
- Dynamic Braking
- Movable, Removable Platform Control
- Nickel Plated Pins
- Lubrication Free Scissor Arm Bushings
- Scissor Maintenance Prop
- 22 in. (55 cm) Foot-Actuated Deck Extension
- Removable Ladder
- Self Closing Gate
- Load Sensing System

Accessories & Options

- Anti-Vandalism Package
- Coiled Platform Control Box Cable
- Flashing Amber Beacon - LED
- Dual Flashing Amber Beacons - LED
- JLG™ Mobile Control
- MDI (Ground)
- CleanGuard™

ES SERIES - LIGHTWEIGHT

ES1330L/ES1530L ELECTRIC SCISSOR LIFTS - INDOOR AND OUTDOOR RATED



Dimensions

All dimensions are approximate.

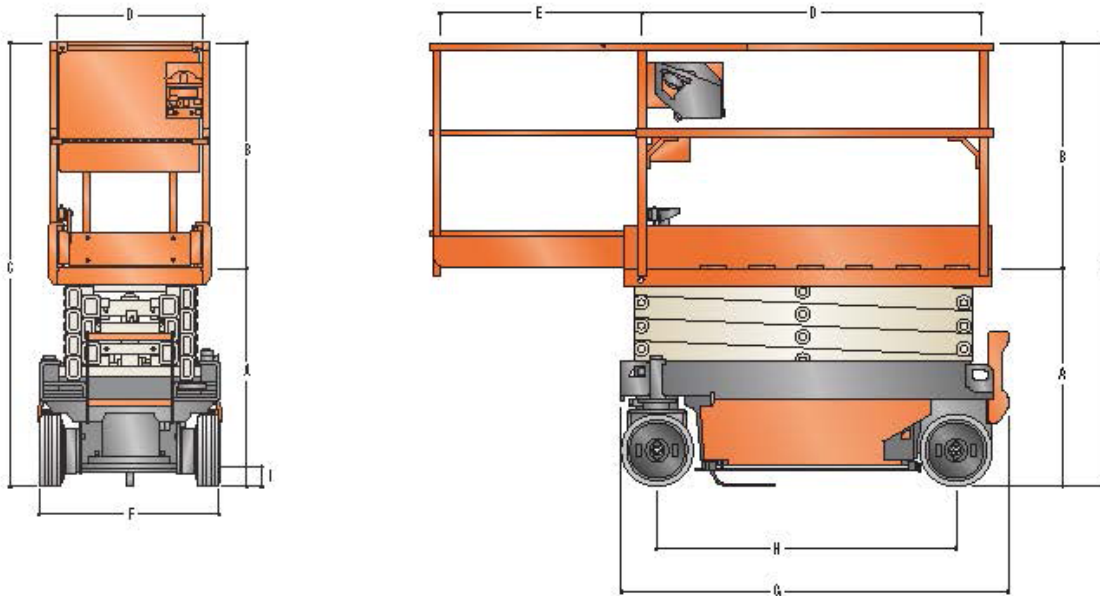

A. Platform Height—Lowered			E. Platform Extension	21.6 in.	55 cm
ES1330L	28.0 in.	0.7 m	F. Overall Width	30.0 in.	76 cm
ES1530L	31.1 in.	0.8 m	G. Overall Length	56.2 in.	14 m
B. Platform Railing Height	43.3 in.	1.1 m	H. Wheelbase	42.3 in.	11 m
C. Overall Height			I. Ground Clearance	2.4 in.	6 cm
ES1330L	71.7 in.	1.8 m			
ES1530L	74.8 in.	1.9 m			
D. Platform Size	244 x 49.2 in.	0.6 x 1.3 m			



The JLG "1 & 5" Warranty

We provide coverage for one (1) full year, and cover all specified major structural components for five (5) years. Due to continuous product improvements, we reserve the right to make specification and/or equipment changes without prior notification. This machine meets or exceeds applicable ANSI and CSA requirements based on machine configuration as originally manufactured for intended applications. Please reference the serial number plate on the machine for additional information.

Part No.: 3131508
R0420_A92.20
Printed in USA

JLG Industries, Inc.
1 JLG Drive
McConnellsburg, PA 17233-9533
Telephone 717-485-5161
Toll-free in US 877-JLG-LIFT
Fax 717-485-6417
www.jlg.com
An Oshkosh Corporation Company