

PB2210 EVO

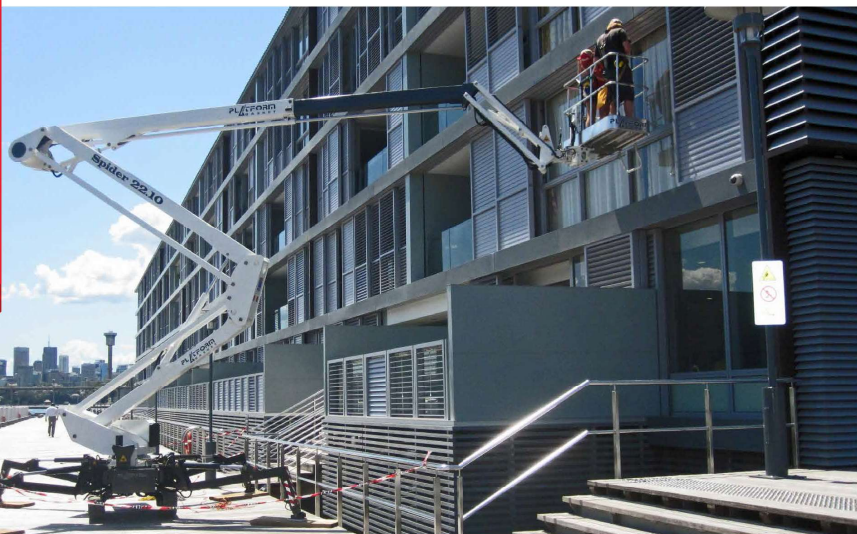

Excellent up-and-over reach with modern double-knuckle technology, and adjustable fly-jib for extra manoeuvrability.

The 2210 also has the most unique ability to rotate a complete 360 degrees and provides full working height even when the stabiliser legs are set in their narrow position.

With the basket removed and tracks in narrow position, the 2210 allows for doorway access. Weighing only 3 t, the 22 m Spider Lift is ideally suited for use on load-sensitive surfaces. The radio control feature allows all functions to be controlled from the basket (or any other position). This includes driving, setting the stabilizer legs and operating the booms, making the 2210 exceptionally operator-friendly.

Compact dimensions + light weight = transportability! The 2210 is available on a very strong tilt-bed trailer weighing in at under 4.5 t.

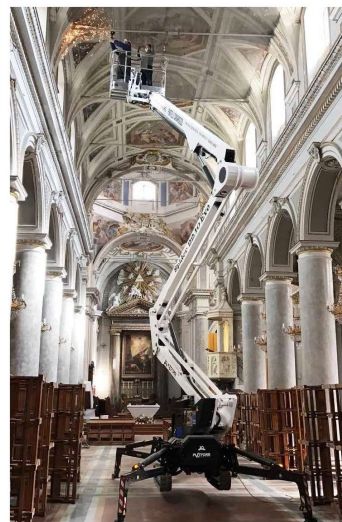

Far left: The 2210 has a very light footprint.

Top: The arborists dream machine with huge up and over reach and large SWL.

Above: The 2210 is incredibly compact.

Left: Dual power and compact dimensions make the 2210 an ideal choice for indoor tasks.

Opposite page: Purpose built 4.5 t GVM tri-axle tilt trailer designed for the 2210.

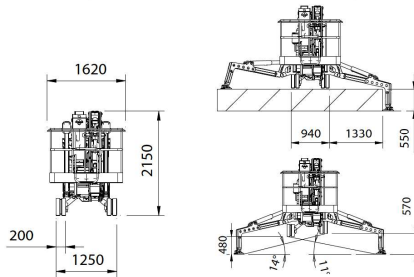
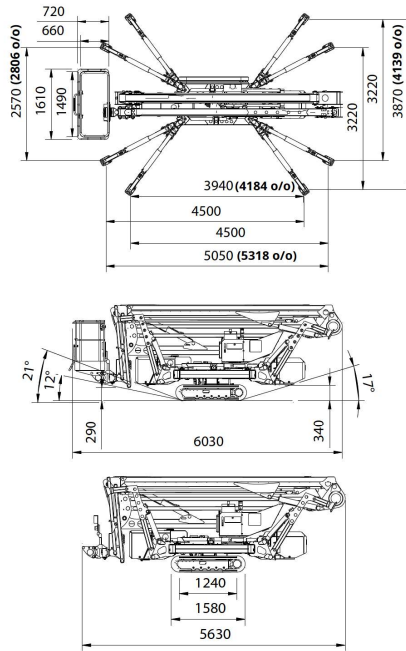
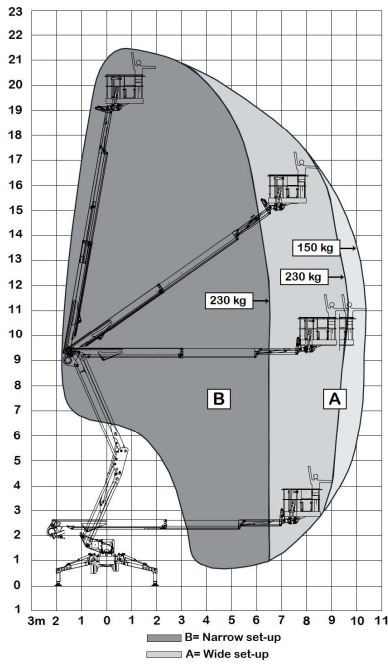

PB2210 EVO

Max working height	21.70 m
Max working height in narrow set	21.70 m
Max horizontal outreach	10.30 m
Max SWL	230 kg
Weight: Engine + 240v	ED 2980 kg
: Engine + Batteries	LBD 3180 kg
Turret rotation	365 °
Basket rotation	180 °
Ground pressure driving (approx)	65 kN/m ²
Max stabiliser force	20 kN
Max stabiliser pressure (std foot pad)	500 kN/m ²
Traffic load (live load) travelling	3.35 kN/m ²
Traffic load (live load) stabilised wide	2.18 kN/m ²
Traffic load (live load) stabilised narrow	2.02 kN/m ²
Auto levelling	Std
Max slope for stabilisers (no extra pads)	17 °
Gradeability lengthwise	16 °
Gradeability sideways	15 °
Standard power source	Kubota 14 Hp Diesel
Optional power source	Honda Petrol
Dual power options	240V Electric or Batteries
Expanding tracks	Std
Drive Speed	2.5 km/h
Radio control	Std
Electric emergency lowering	Std

(All specs E&OE and subject to change)

SEE THE 2210
IN ACTION

